



Climar

HOME

*La simplicité de la ligne Home vous permet d'avoir recours à votre imagination et créer votre espace à votre image.*

*Les couleurs et les formes permettent un encadrement facile dans n'importe quel ambiance.*

*Afin d'obtenir une meilleure combinaison, vous devez utiliser le schéma de codification, sur lequel vous devez vous pencher sur quatre champs différents: le premier correspond à la forme de l'abat-jour, le deuxième à la couleur de celui-ci, tandis que le troisième et le quatrième sont relatifs à la forme et à la couleur de la structure de la lampe, respectivement.*

*Ainsi, vous pourrez obtenir le code du luminaire que vous souhaitez.*

*La simplicidad de la línea Home, le da libertad para usar la imaginación y crear su espacio a su imagen.*

*Los colores y las formas permiten un fácil encuadre en cualquier ambiente.*

*Para obtener la mejor combinación, debe utilizar el esquema de codificación, donde hay que dar atención a cuatro campos distintos: el primero corresponde a la forma y dimensiones de la pantalla, el segundo su color, mientras que el tercero y cuarto se refieren respectivamente a la forma y color de la estructura base de la lámpara.*

*De esta forma podrá obtener la lámpara que pretende.*

*Home range simplicity gives you freedom to use your imagination and create a personalized space.*

*Diversity of colours and shapes allowing a perfect match to any room interior.*

*The best combination is obtained using the encoding scheme, where you must take care to four different fields: first the form and size of the lampshade, second its colour, third and fourth respectively the lamp structure's shape and colour.*

*A comprehensive and simple way to reach the lamp you want.*

*A simplicidade da linha Home, liberta-o para usar a imaginação e criar o seu espaço à sua imagem.*

*As cores e as formas permitem um fácil enquadramento em qualquer ambiente. Para obter a melhor combinação, deve utilizar os esquemas de encomenda, onde tem de tomar atenção a 4 diferentes campos: O primeiro corresponde à forma e dimensão do abatjourn, o segundo à cor do mesmo, já o terceiro e quarto dizem respeito à forma e cor da base estruturante do candeeiro, respectivamente.*

*Desta forma poderá obter o candeeiro que mais o satisfaz.*

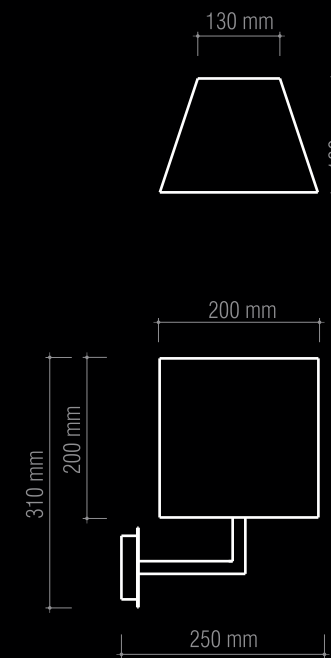

B 200 rosa / F branco



E27



CE 230V/50Hz EN 60 598  IP20

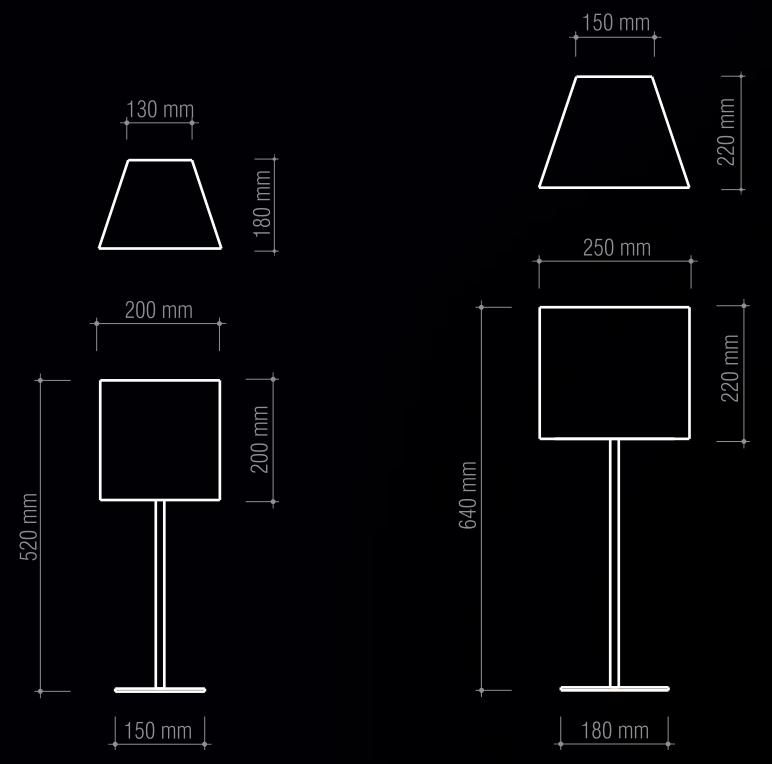

     
CE 230V/50Hz EN 60 598  IP20

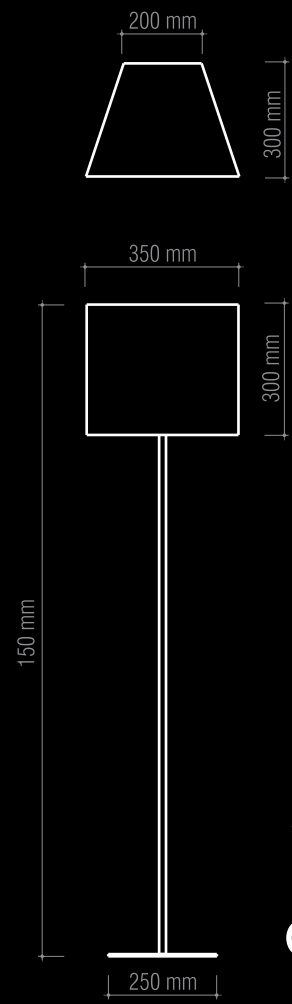

CE 230V/50Hz EN 60 598 IP20

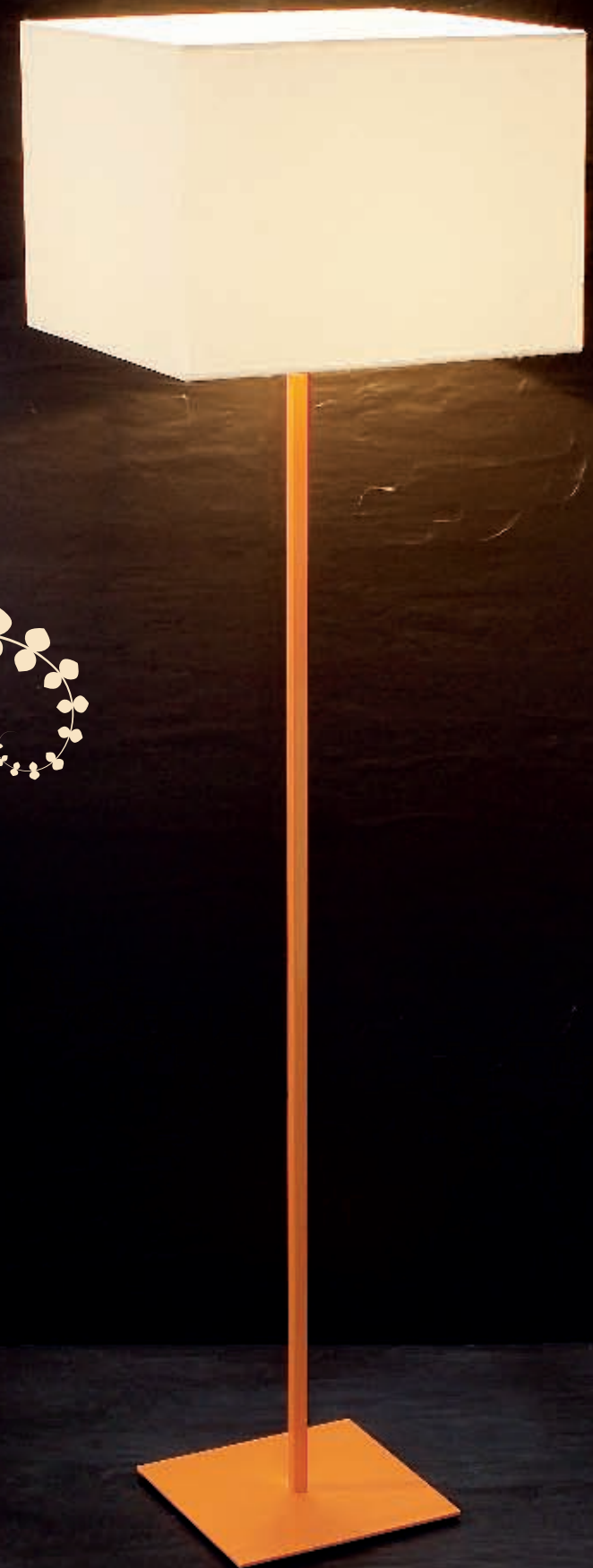

B 200 rosa / F branco



E27

recomendada  
recommended



CE 230V/50Hz EN 60 598 IP20

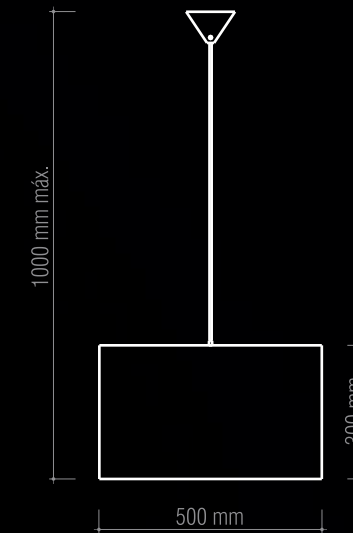
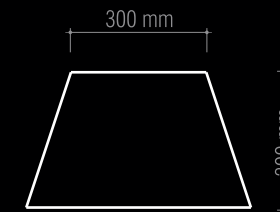

## abatjour lampshade pantalla abat-jour

4 modelos x 4 dimensões x 9 telas

4 lampshade models x 4 different sizes x 9 fabric types

4 modelos de pantalla x 4 tamaños x 9 tipos de tela

4 modèles abat-jour x 4 tailles x 9 types de toile

### A. Abatjour cónico quadrangular

A. Quadrangular tapered lampshade

A. Pantalla cónica cuadrangular

A. Abat-jour coniques carré

### B. Abatjour cónico circular

B. Circular tapered lampshade

B. Pantalla cónica circular

B. Abat-jour coniques circulaire

### C. Abatjour circular

C. Circular lampshade

C. Pantalla circular

C. Abat-jour circulaire

### D. Abatjour quadrangular.

D. Quadrangular lampshade

D. Pantalla quadrangular

D. Abat-jour carré

formas shapes formas formes

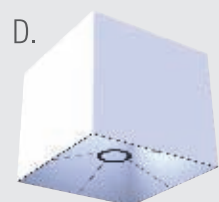
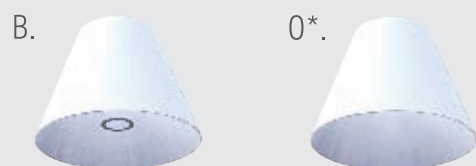
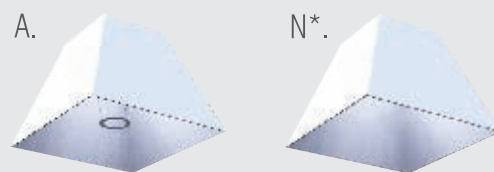

\* Exclusivo para Suspensão  
Suspended only  
Solo colgante  
Suspension seulement

ref.

A 250  
A 300  
A 400  
A 500  
N 400\*  
N 500\*

B 250  
B 300  
B 400  
B 500  
O 400\*  
O 500\*

C 200  
C 250  
C 350  
C 500

D 200  
D 250  
D 350  
D 500

dim. (mm)

a b c

250 130 180  
300 150 220  
400 200 300  
500 300 300  
400 200 300  
500 300 300

250 130 180  
300 150 220  
400 200 300  
500 300 300  
400 200 300  
500 300 300

200 200  
250 220  
350 300  
500 300

200 200  
250 220  
350 300  
500 300



0,20 17,6  
0,26 27,0  
0,46 97,3  
0,54 113,0  
0,46 97,3  
0,54 113,0

0,18 17,6  
0,22 27,0  
0,35 97,3  
0,54 113,0  
0,35 97,3  
0,54 113,0

0,18 17,6  
0,22 27,0  
0,35 97,3  
0,54 113,0

0,20 17,6  
0,26 27,0  
0,46 97,3  
0,54 113,0

ex. :

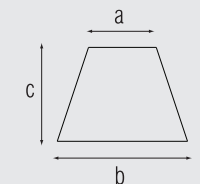

telas fabric tela toile

branco white blanco blanc

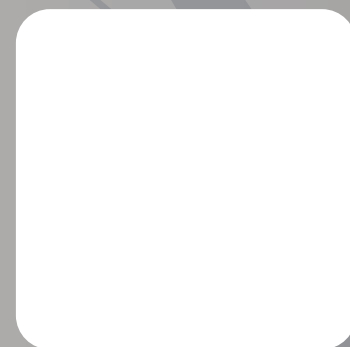

crú raw crudo cru



laranja orange naranja oranje



rosa pink rosa rose

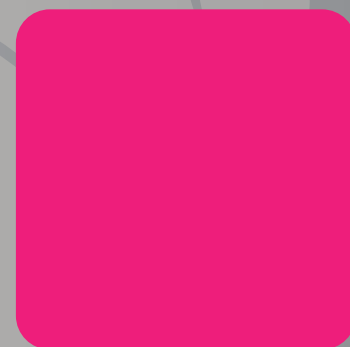

vermelho red rojo rouge



azul blue azul bleu



verde green verde vert



castanho brown marrón marron



preto black negro noir

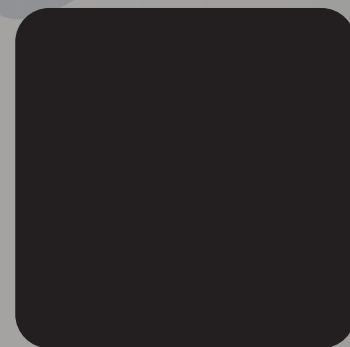

encomenda order pedido commande

ref. + cor colour color couleur

ex. A 200 + rosa

## estrutura *structure* estructura *structure*

9 estruturas disponíveis em 6 cores distintas e com base circular ou quadrada (excepto E – Suspensão).

*9 structure versions available in 6 different colours with circular or square lamp base shape (except E - Suspension).*

9 estructuras disponibles en 6 colores distintas y con base circular o cuadrangular (excepto E - Suspensión).

*9 structures disponibles en 6 couleurs différentes sur base circulaire ou carrée (sauf E - Suspension).*

### E. Suspensão em termoplástico, disponível em branco e preto

*Thermoplastic suspension, available in white and black*

*Suspensión de termoplástico, disponible en blanco y negro*

*Suspension thermoplastique, disponible en blanc et noir*

(abatjourns sugeridos: N400, N500, O400, O500, C350, C500, D350, D500)

*suggested lampshade pantallas sugeridas abat-jour suggéré*

### F/G. Aplique de parede pintado

*Wall mounted Applique de pared Applique murale*

(abatjourns sugeridos: A250, B250, C200, D200)

*suggested lampshade pantallas sugeridas abat-jour suggéré*

### H/I. Candeeiro de mesa de cabeceira

*Bedside table lamp Lámpara de mesita de noche Lamp de chevet*

(abatjourns sugeridos: A300, A400, B300, B400, C250, C350, D250, D350)

*suggested lampshade pantallas sugeridas abat-jour suggéré*

### J/K. Candeeiro de mesa

*Table lamp Lámpara de sobremesa Lamp de table*

(abatjourns sugeridos: A300, A400, B300, B400, C250, C350, D250, D350)

*suggested lampshade pantallas sugeridas abat-jour suggéré*

### L/M. Candeeiro de pé

*Floor-standing lamp Lámpara de pie Lampe sur pied*

(abatjourns sugeridos: A400, A500, B400, B500, C350, C500, D350, D500)

*suggested lampshade pantallas sugeridas abat-jour suggéré*

ref.

E.

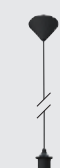

F.



G.



H.



I.



J.



K.



L.



M.

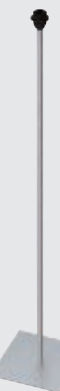

cores *colours*  
colores *couleurs*



dim. (mm)

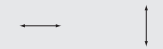

ajustável até  
máx.800

150

100

150

320

180

390

250

1270

ex. :

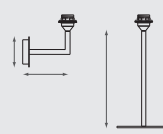

0,09

8,0

0,40

9,6

1,00

16,8

1,40

26,0

3,10

127,8

laranja *orange* naranja *orange*



rosa *pink* rosa *rose*

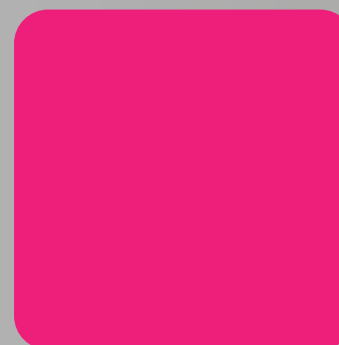

branco *white* blanco *blanc*

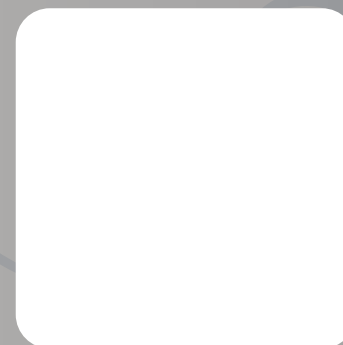

beije *beige* beins *beige*

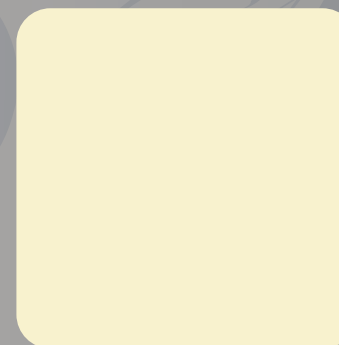

preto *black* negro *noir*

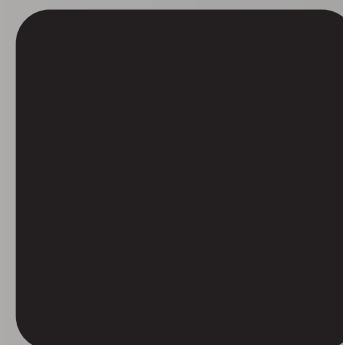

cinza *grey* gris *gray*



**encomenda** *order* pedido *commande*

ref. + cor *colour* color *couleur*

ex. F + preto

# www.climar.pt



**Climar - Indústria de Iluminação, S.A.**

Add · Rua Estrada Real, Nº 50  
3750-866 Borralha · PORTUGAL  
N 40°32'44" | W 8°27'11"

PO Box · Apartado 170  
3754.909 Águeda · Portugal

Tel · +351. 234 690 330

Fax · +351. 234 601 974

email · [geral@climar.pt](mailto:geral@climar.pt)

internet · [www.climar.pt](http://www.climar.pt)



QUADRO  
DE REFERÊNCIA  
ESTRATÉGICO  
NACIONAL

**iacom**  
energia



[www.iacomgrupo.com](http://www.iacomgrupo.com)